

INDUSTRIAL AUTOMATION – A MODERN PERSPECTIVE

Ankita Goyal¹, Prof. Neha Sharma²

Department of Electronics and Communication Engineering, Ujjain Engineering College, Ujjain M.P. (INDIA) ^{1,2}

goyalankita07@gmail.com¹, nehatripathi@yahoo.com²

Abstract

Despite years of activity, truly open and intelligent control systems seem still to be a promise of the future. Agreement on common architectures and application objects is needed to raise open control systems from exchanging raw data to the level of real interoperability of off-the-shelf components. Future control platforms and programming languages should have new built-in mechanisms that support implementation of intelligent functions, such as flexible resource management and exception handling. This article argues that many of these challenges can be met by taking full advantage of emerging software engineering technologies. This also means that the modeling techniques and design practices of software engineering should be combined with the traditional ways of thinking in automation.

Generals Term

Industrial automation, PLC, LAN, SCADA

Keywords

CAN (Control Area Network), GUI (Graphical User Interface), and IAS (Industrial Automation System).

INTRODUCTION

Industrial automation spans a broad field of applications from product automation to industrial plants. For all these applications, there are numerous challenges to be faced like reduced time-to-market, reduced costs, increased variability and expectations concerning higher quality. Domain engineering has been developed for software and offers a good approach for meeting these requirements, since it is based on reusability. Unfortunately, the adoption of this approach to industrial automation systems is not possible without major changes. Industrial automation possesses distinguishing characteristics, which require deeper research and new methodologies, in order to enable a systematic reuse. A new approach, based on the domain engineering approach applied for software, is being currently developed. The new approach considers the characteristics of industrial automation by taking not only software into account, but also hardware and the knowledge necessary to develop new industrial automation systems. The approach addresses three areas: CAN, GUI and MATLAB.

TRADITIONAL APPROACHES

Industrial automation is normally deployed in industries with the purpose of enhancing safety, comfort, communication and power saving with less human interaction. It usually consists of sensors and actuators. Sensor is used to collect data from the physical environment while actuators are meant to make decisions based on the information gathered by the sensors [3]. A network is also required for the purpose of establishing communication between sensors and actuators [4]. As the technologies become advances, the current automation system has been developed to be more flexible and adaptable to the changing scenario [5].

From the rapid advancement in technology, various type of information can be shared easily, efficiently, and effectively through networking. There are many communication networks

such as local area network (LAN), power line communication, ZigBee and so on are suitable to be implemented as the smart home network. LAN generally provides high-bandwidth communication over inexpensive transmission media such as twisted pair, coaxial cable and fiber optic. However, a set of software protocols which is necessary to be implemented in the host computers to enable the LAN to transmit and receive the control data from one host or device to another via the transmission mediums of the network. The software protocols are the integral part which functions at various levels, starts from low level packet transport protocols to high-level application protocols [6].

Traditionally, power lines are only intended for conveying electrical power to devices and not designed for delivering high-frequency signals. Although the advancement of signal modulation and error control coding techniques have made power line communication (PLC) become possible [7], it is not suitable for signal transmission due to noise and interference in the power line channel. Consequently, power line signal transmission will encounter variety of characteristic impedances. ZigBee is the first industrial standard using wireless personal area network (WPAN) technology that provides short range, low power and low data rate communication, and also supports mesh networking and multihopping. However, ZigBee networks are primarily intended for low duty-cycle sensors especially for those active for less than 1% of the time [8], [9].

Power Line Communication

The first IAS using PLC was installed in Kyong-Gi District Head Office in 1983. This system uses two-way data transmission over the 22.9 kV industrial networks. At the substation, signals are injected onto the 22.9 kV industrial network and 42 automatic switches in two substations have been remotely controlled. However, the signal transmission speed was too slow compared w media. In the case of frequent changes of industrial lines like underground construction and load transfer, the change of communication path often causes transmission failure, which is called "open circuit problem." In other words, communication is lost with devices on the far side of an open circuit. This severely restricts the usefulness of PLC systems for applications involving recloses, switches, sectionalizes, and outage detection. PLC systems also require that a signal transmitter/receiver be installed in all industrial substations that have a downstream PLC device. These are expensive and can have significant negative impact on the cost effectiveness of PLC solutions. Recently, a new technology using high frequencies is being developed and under field test, with the advantage that utilities do not need to invest for additional communication network.

Pair Cable

The prototype of Korean IAS (KOIAS) was developed jointly by KEPCO Research Institute (KEPRI), Korea Electro technology Research Institute and six industrial partners from 1991 to 1993, as a national research project to enhance the competitiveness of domestic manufacturing industry. To evaluate in the real field, the prototype was installed in Kang-Dong Branch Office (B/O) in Seoul and in operation since 1994. As a communication media, 70 km-long pair cables were constructed and 125 automatic switches were installed to verify the remote control functions. The other SCAIA system using pair-cable has been in operation to study its performance and applicability to industrial line. The 122 automatic switches in 22 kV- underground industrial lines have been remotely controlled in Chong-Boo B/O in downtown Seoul. Due to the low efficiency and poor reliability, pair cable has not been extended any more.

Telephone Line

The demonstration system using telephone line was installed in Ulf Reung in 1997. Upon evaluation of the model system, it has been expanded to eight B/Os in rural area since 1998 and recently, and about 19% of automatic switches have been controlled by telephone line. The advantage of telephone line is its wide service area all over the country. However, different ownership of the line and equipments often cause the delay of service restoration. Some intermittent communication errors still need to be improved continuously. These days, telephone lines are used less because of the costs associated with installation of telephone lines and dielectric isolation equipment, and also due to the monthly cost. The cost for installation of telephone lines is increasing with the remoteness of the location.

Wireless Data Communication

Wireless solutions have shown the greatest potential for automating industrial networks because they communicate virtually anywhere at a very low cost. A demonstration system using a private wireless network was developed and installed in Gyong-GiB/O to test the feasibility of data communication. Upon evaluation of the model system, IA using wireless data service has been expanded in their possible service areas. However, the service area of wireless data communication network is restricted to some big cities for their commercial use, and data communication response had been delayed during peak time intervals like an opening time of the stock exchange market.

Fiber Optic Solution

Fiber-optic cable is a very technically attractive solution, offering relatively unlimited bandwidth. Its dielectric and

EMI/RFI noise immunity characteristics make it an ideal fit in the high-voltage operating environment. While fiber optic solutions are expensive, they offer two large benefits: first it allows utilities to bring back large amount of data on a frequent basis. Second, it can provide true, real-time communications. These benefits make fiber optic communications an attractive alternative if getting large amounts of data on a real time basis is critical and the location is not extremely remote. KEPCO itself possesses a huge backbone network covering the GW (composite ground wire with optical fiber). Large-scale D whole country with OPAS in urban area needs high reliability and high-speed because it needs to process a large amount of data in a short time compared with small-scale IAS in rural area with more dispersed facilities. About 57% of automatic switches in large cities have been remotely controlled, showing the best reliability and communication speed among all other communication media.

CAN OVERVIEW

Controller Area Network or so-called CAN is a serial bus that utilizes broadcast method to transmit messages across all CAN nodes. It uses a serial control protocol which provides reliable, efficient and economic link between devices to support the distributed real time applications by using a bitwise deterministic collision-resolution mechanism.

It was originally developed in the 1980s by Robert Boush as an alternative data communications for interconnecting the control components in automotive vehicles. Prior to CAN technology, all manufacturers used to connect devices within vehicles using point to point wiring systems. Wiring started to become more complex, bulky, heavy and expensive as more electronics and controllers are deployed in a vehicle. This problem can be seen in Figure 1(a), where the abundance of wiring is required which makes the whole circuit even more complicated. CAN system can solve this problem by utilizing a twisted pair cable to communicate with each other as shown in Figure 1(b).

Initially, it was designed to allow the microcontrollers and devices to communicate with each other within a vehicle without a host computer. It has been fast gaining wide appreciation with further applied in various automation industrial including military, aviation, electronics, factories and many others due to its high immunity towards electrical interference, and the ability to self diagnose and repair the data errors. Additionally, the low cost, performance and upgradeability to provide tremendous flexibility in the system design add to its many advantages.

CAN Protocol

The CAN system uses carrier sense multiple access with collision detection (CSMA/CD) and arbitration on message

priority as its communication protocol. This communication protocol allows every node in CAN to monitor the network bus in advance before attempting to transmit a message.

When no activity occurs in the network, each node has the same opportunity to transmit a message. Additionally, this communication protocol allows collision to be solved by using bit-wise arbitration. It is based on a pre-programmed priority of each message in the identifier field of a message. This configuration allows the messages to remain intact after the arbitration is completed even if collisions are detected. In order for the arbitration process to be successful, the logic states need to be defined as dominant or recessive. An example of CAN arbitration can be seen when three nodes are assumed to be transmitting simultaneously.

When three nodes start transmitting their start of frame (SOF) bits simultaneously, the Nodes 1 and 2 stop transmitting as soon as they transmit bit '1' (recessive level) while Node 3 is transmitting bit '0' (dominant level). At this instance, Node 3 will continue its transmission when the identifier of bit '0' has been transmitted while Nodes 1 and 2 are entering into the receiver mode which indicated in grey color. The CAN protocol is defined with the ISO standard of 11-bit identifier that provides for the signaling rates from 125 kbps to 1 Mbps. This standard is later improved to allow for larger number of bit with the "extended" version of 29-bit identifier. The 11-bit identifier standard provides 2^{11} or 2048 different message identifiers while the extended 29-bit identifier standard provides 2^{29} or 537 million identifiers ^[9].

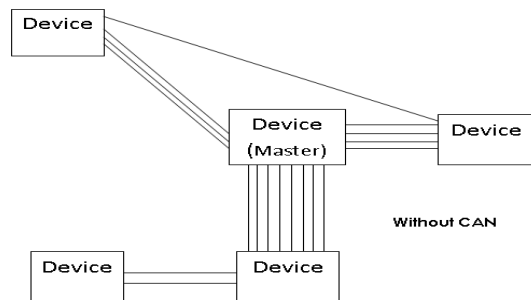

Fig. 1 (a) Traditional Wiring

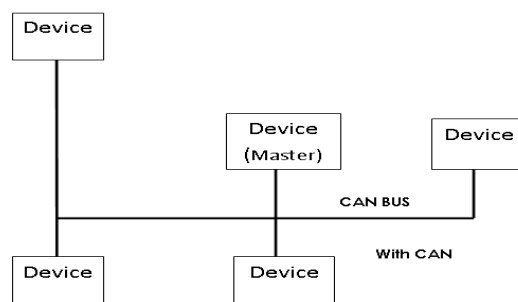

Fig. 1 (b) CAN Wiring

CAN in Matlab

Vehicle Network Toolbox™ provides connectivity to CAN devices from MATLAB® and Simulink® using industry-standard CAN database files. The toolbox provides MATLAB functions and Simulink blocks to send, receive, encode, and decode CAN and XCP messages, enabling you to exchange messages between a CAN bus and your programs and models. It also can connect to an ECU via XCP on CAN using A2L description files. From MATLAB or Simulink, we can monitor, filter, and analyze live CAN bus data or log and record messages for later analysis and replay. Also simulate message traffic on a virtual CAN bus or connect Simulink models to a live network or ECU. Vehicle Network Toolbox supports CAN interface devices from Vector, Kvaser, and National Instruments.

PROPOSED WORK

Getting the details from the above discussion a new, innovative and modern perspective approach on industrial automation is suggested. In our proposed work we have decided to design a GUI (Graphical User Interface) system built on Matlab that will provide the link up with CAN bus. For the said purpose it has been decided to use the Vehicular network Toolbox in Matlab. The Matlab GUI will send and receive data from the CAN environment and repository mechanism to effectively utilize the information will be deployed.

For the whole setup primary issues would be the fetching and retrieval of old messages and also developing a GUI which should be very easy for the lame operator in the industrial setup to operate. The said system can work as an alternative to PLC and other automation processes.

CONCLUSION

In this research article, a comprehensive approach toward industrial automation has been taken. Several methods were evaluated on the basis of cost and performance. In addition to that a new system based on Control Area Network has also been discussed. The proposed system is under development and GUI (graphical user interface) for the same has to be developed. Also all the technological solutions have been discussed keeping in view Indian scenario and development state in our country.

7. REFERENCES

- [1]. M. G. Golzar, and H. Tajozakerin, "A New Intelligent Remote Control System for Home Automation and Reduce Energy Consumption," *Fourth Asia International Conference on Mathematical/Analytical Modelling and Computer Simulation (AMS 2010)*, pp. 174 - 180, 26 - 28 May 2010.
- [2]. D. D. Clark, K. T. Pogran, and D. P. Reed, "An Introduction to Local Area Networks," *Proceedings of the IEEE*, vol. 66, no. 11, pp. 1497 - 1517, 1978.
- [3]. K. S. Surendran, and H. Leung, "An Analog Spread-Spectrum Interface for Power-Line Data Communication in Home Networking," *IEEE Transactions on Power Delivery*, vol. 20, no. 1, pp. 80 - 89, Jan. 2005.
- [4]. S. Dagtas, G. Pekhteryev, and Z. Sahinoglu, "Multi-Stage Real Time Health Monitoring via ZigBee in Smart Homes," *21st International Conference on Advanced Information Networking and Applications Workshops (AINAW 2007)*, vol. 2, pp. 782 - 786, 21 - 23 May 2007.
- [5]. X. H. Li, K. L. Fang, J. G. Gu, and L. Zhang, "An Improved ZigBee Routing Strategy for Monitoring System (ICINIS 2008)," *First International Conference on Intelligent Networks and Intelligent Systems*, pp. 255 - 258, 1 - 3 Nov. 2008.
- [6]. R. B. GmbH, "CAN Specification," version 2.0, 1991.
- [7]. K. Pazul, "Controller Area Network (CAN) Basics," *Microchip Technology Inc*, 1999.
- [8]. S. Corrigan, "Introduction to the Controller Area Network (CAN)," *Texas Instrument, Application Report*, July 2008.
- [9]. M. Farsi, K. Ratcliff, and M. Barbosa, "An Overview of Controller Area Network", *Computing & Control Engineering Journal*, vol.10, no. 3, pp. 113 - 120, August 1999.
- [10]. J. Liu, G. Y. Hu, and X. H. Wen, "DSP and CAN Bus Based Induction Motor Control in Electrical Vehicle Application," *Sixth International Conference on Electrical Machines and Systems (ICEMS 2003)*, vol. 2, pp. 585 - 587, 2003.